

'KESIN' Cast Iron Double Flanged Swing Check Type Reflux Valves Multi Door Pattern (400mm - 1200mm)



Reflux Valves are generally used in rising mains to check return flows. In large diameter pipes, the door, in single door pattern would close slowly and reflux flow would cause water hammer due to surge. Therefore multi-door pattern is resorted to in such cases, so as to reduce the time required for closure. The flow may be controlled by means of flaps swinging up and down with pressure on the seats. (Swing Check). The minimum number of doors in the diaphragm plate shall be two.

Reflux valves are designated by nominal pressure defined as the maximum permissible gauge working pressure in MPa as under.

PN-0.6 & PN-1.0

Table 10 : Materials for Different Component Parts of Reflux Valves

Sl. No.	Component	Basic Materials	Grade or Designation	Alternative Material	Grade or Designation
1.	Body with hinge and diaphragm	Grey Cast Iron	FG 200	a) S.G. Iron b) Cast Iron	400/12 Grade B
2.	Hinge Pin	High Tensile Brass	HT 2 FHTB 1	Stainless Steel Steel	04 Cr 17 Ni 12 Mo 2 or 04 Cr 18 Ni 10 12 Cr 13
3.	Bolts	Carbon Steel	Class 4.6	--	--
4.	Nuts, Nuts for Hinge Pins	Carbon Steel	Class 4	--	--
5.	Bearing Bushes	Leaded Tin Bronze	LTB 2	a) Austenitic Iron b) PTFE	ASGN : 20
6.	Face and Seat Rings	Leaded Tin Bronze	LTB 2	a) Austenitic Stainless Steel b) Stainless Steel	04 Cr 17 Ni 12 Mo2 or 04 Cr 18 Ni 10 12 Cr 13
7.	Flange joining materials	Rubber	--	--	--





'KESIN' Cast Iron Double Flanged Swing Check Type Reflux Valves

The tolerances on the face-to-face dimensions shall be as follows :

Face-to-face Dimensions	Tolerances
400mm	± 2mm
Above 400mm up to and including 600mm	± 3mm
Above 600mm up to and including 800mm	± 4mm
Above 800mm up to and including 1000mm	± 5mm

By-Pass Connection - By-Passes are not standard items on valves to the design, but if required, they are made for connection between the inlet and outlet of the valve. By passes shall conform to PN-1 of IS : 14846* and the minimum size of the by-pass arrangement shall be as indicated below :

Size of Valve	Min. Size of By-Pass Arrangement
400 mm	50 mm
450 mm to 600 mm	80 mm
700 mm to 1200 mm	100 mm

* see page 15, Table - 4

Mass of Valves - The minimum finished mass of the valves shall be as follows :

Nominal Size of Valve (mm)	Min Mass (kg)
500	1450
600	2040
700	2250
750	2450
800	2540
900	3480
1000	4000
1100	5100
1200	6000

Table 11 : Test Pressure & Test Duration of Valves

PN Rating	Test for kg/cm ²	Test Pressure Minutes	Test Duration
PN - 0.6	Body Test	9	2
	Seat Test	6	2
PN - 1	Body Test	15	2
	Seat Test	10	2

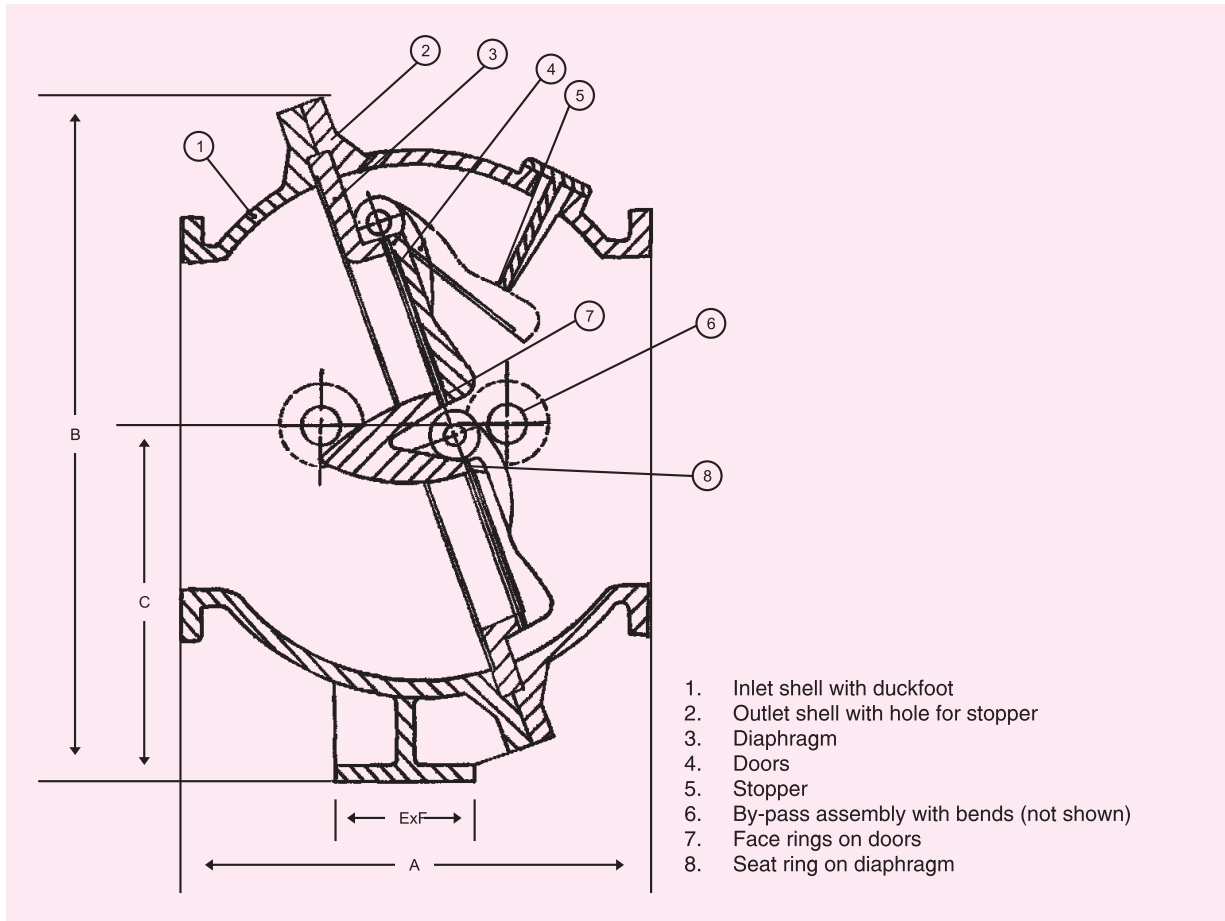

Fig. 14 : Typical Multidoor

Table 12 : Dimensions

DN	Length Over	Overall Height	Height of Centre	Size of Duck
500	815	1150	600	200 x 250
600	914	1333	685	254 x 254
700	1000	1446	750	300 x 375
750	1045	1446	750	300 x 375
800	1118	1634	850	300 x 375
900	1250	1570	815	300 x 375
1000	1250	1730	915	300 x 375
1100	1396	2069	1080	400 x 450
1200	1500	2250	1175	400 x 450

